

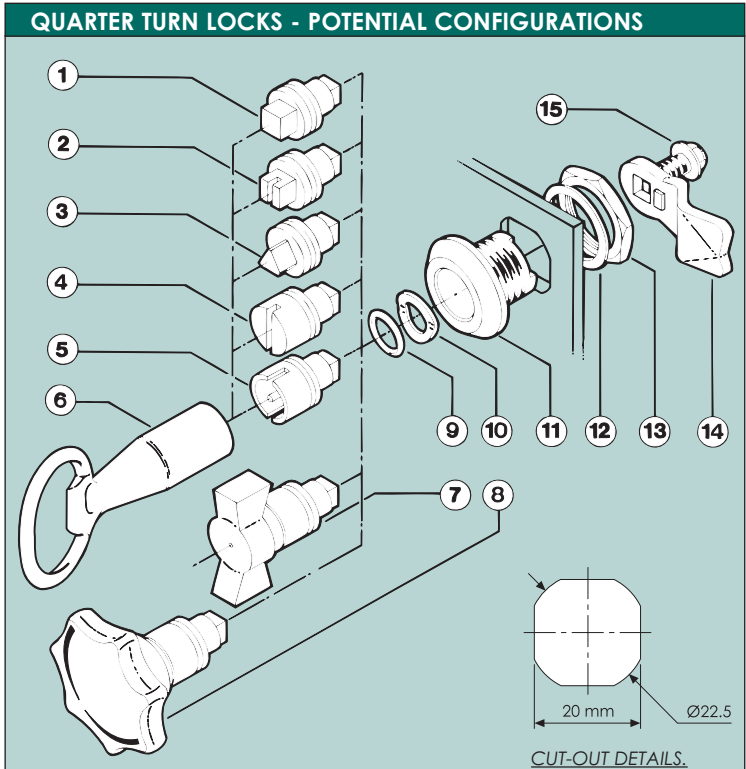

Brochure listing all available configurations and part numbers available on request.



1.	8 mm Square.	2.	8 mm Square slotted.
3.	7 & 8 mm Triangular.	4.	2 x 4 mm deep slot.
5.	3 & 5 mm Double bit.	6.	Key to suit insert.
7.	Wing-knob.	8.	Star handle.
9.	'O' ring.	10.	Wavewasher.
11.	Housing.	12.	External seal.
13.	Nut or earth-nut.	14.	Cam.
15.	Screw.		

Inserts 1 to 5 are in a variety of finishes which include chrome plate, black powder-coating and black polyamide.

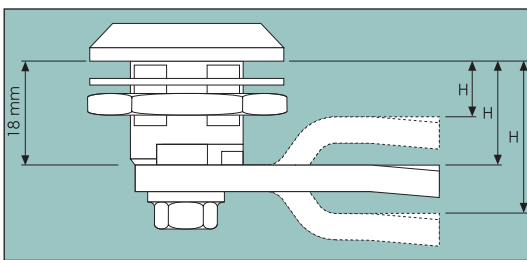

For suitable cam please contact us with dimension H.

• FINISHES • FINISHES • FINISHES • FINISHES • FINISHES •

28 mm	ZINC-ALLOY, DIE-CAST.	ZINC-ALLOY, DIE-CAST.	POLYAMIDE
32 mm	CHROME PLATED	BLACK POWDER-COATED	BLACK

With die-cast body only, dimension A is available 30mm, 36mm, 40mm, 50mm and 60mm.

